

Energy Division

Bowthorpe EMP surge arrester  
Distribution metal oxide surge arrester  
DA1 Series, (IEC)

Tyco Electronics Bowthorpe EMP business unit pioneered the development of polymeric composite housed surge arresters in the early 1980's and since then has a proven service experience across the globe, operating in the worlds toughest environments.

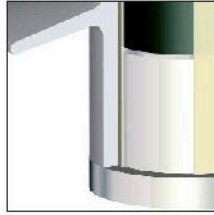

**Sealing:**

All arrester cores are encapsulated in silicone insulating housing. A permanent chemical bond connects the arrester core and the non-tracking silicone housing. This invisible interface prevents moisture from entering during severe thermal fluctuations due to normal climatic and energy absorption events.

Bowthorpe EMP surge arresters provide active over voltage protection that contributes directly to improved reliability of your system, reducing lost minutes and protecting expensive assets.

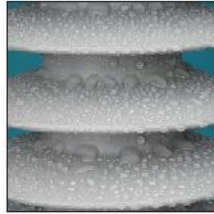

**Polymer housing:**

Non-tracking and hydrophobic silicone insulating material is used for DA arrester housings. The DA surge arrester series is available with standard or extra creepage distance. The housing material has proven performance in long term TERT and UV aging tests and proven resistance to flammability.

Bowthorpe EMP DA silicone surge arresters have been designed and tested to meet our customers demands with reliability and offering improved operational performance. The DA development was based on 30 years of experience in arrester design and manufacture within the Tyco Electronics Energy Division.

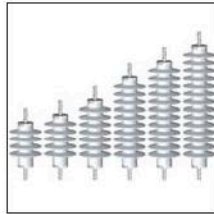

**Integrated design:**

Manufacturing integrates all components in a single piece. There are no glued interfaces. The design is void and gap free ensuring peak performance under the harshest conditions.

The DA1 series is qualified to the latest revision of IEC 60099-4, 2006 and all our reports are independently certified.



**Reliable and consistent ELD**

Our robust earth lead disconnect, (ELD) offers operational reliability and consistency. It was designed to operate in event of arrester failure, removing earth connection and fault from line. It can be shipped and stored restriction free.

- The Bowthorpe EMP DA surge arrester is made possible by:
- 1) Proven moisture sealing technology
  - 2) Non-tracking insulating silicone materials.
  - 3) Fully integrated, single piece and void-less design.
  - 4) Reliable earth lead disconnect
  - 5) Safe mode of failure
  - 6) Quality



**Safe mode of failure:**

Our high energy arresters are tested in accordance with the pre-failing mode of failure test in IEC 60099-4, 2006. This testing has proven the DA1 surge arrester series safe and predictable failure characteristics.



**Quality:**

The DA1 series arrester is manufactured to international quality standards in Tyco Electronics production facilities. We perform 100% routine testing on arresters:

- 1) Visual inspection
- 2) Reference voltage test
- 3) Partial discharge test

**Summary of DA1 series surge arrester technical characteristics**

Ur (kV)	4 - 45
In (kA)	10
High current impulse (kA)	100
DA1 energy (according to IEC 99-4, 8.5) (kJ / kV)	5.6
Long duration current (A / μs)	325 / 2000
10s TOV (kV)	1.29 * U <sub>c</sub>
High current short circuit (kA)	21
Arrester technology	ZnO gapless Mould in place

## Reliability, quality and protection excellence

### Qualification testing:

Decades of insulating materials, arrester design and development experience has been combined to create the DA series arrester. The basic construction comprises of high energy ZnO varistors, assembled within a flame retarded composite laminate tube. The following design IEC 60099-4 design type tests have been carried out on the DA series arresters:

- 1) Insulation withstand tests on the arrester housing
- 2) Residual voltage tests
- 3) Long-duration current impulse withstand test
- 4) Operating duty tests
- 5) Short-circuit tests
- 6) Internal partial discharge tests
- 7) Test of the bending moment
- 8) Moisture Ingress Test
- 9) Weather Ageing Test
- 10) Power -frequency voltage versus time characteristics on an arrester

The silicone insulating material has been designed and optimised for arrester application. The following additional testing was performed in the qualification of the silicone:

- 1) Tracking and Erosion
- 2) UV testing
- 3) Thermal endurance
- 4) Dielectric testing
- 5) Flammability testing.
- 6) Long term water immersion testing

### Production and Quality:

All our arrester production facilities have implemented QC and QA procedures according to international standards to ensure test programs that guarantee quality conforming products. 100% of all Varistors are tested and stamped with unique varistor residual and reference voltage. The following tests are performed on varistors:

- 1) Residual voltage
- 2) Reference voltage
- 3) Leakage current
- 4) Physical examination to screen damaged varistors
- 5) LOT test: High current impulse test
- 6) LOT test: Aging test

At the end of the arrester assembly process, the following mandatory IEC tests are completed on every arrester: visual inspection, reference voltage test and PD testing.

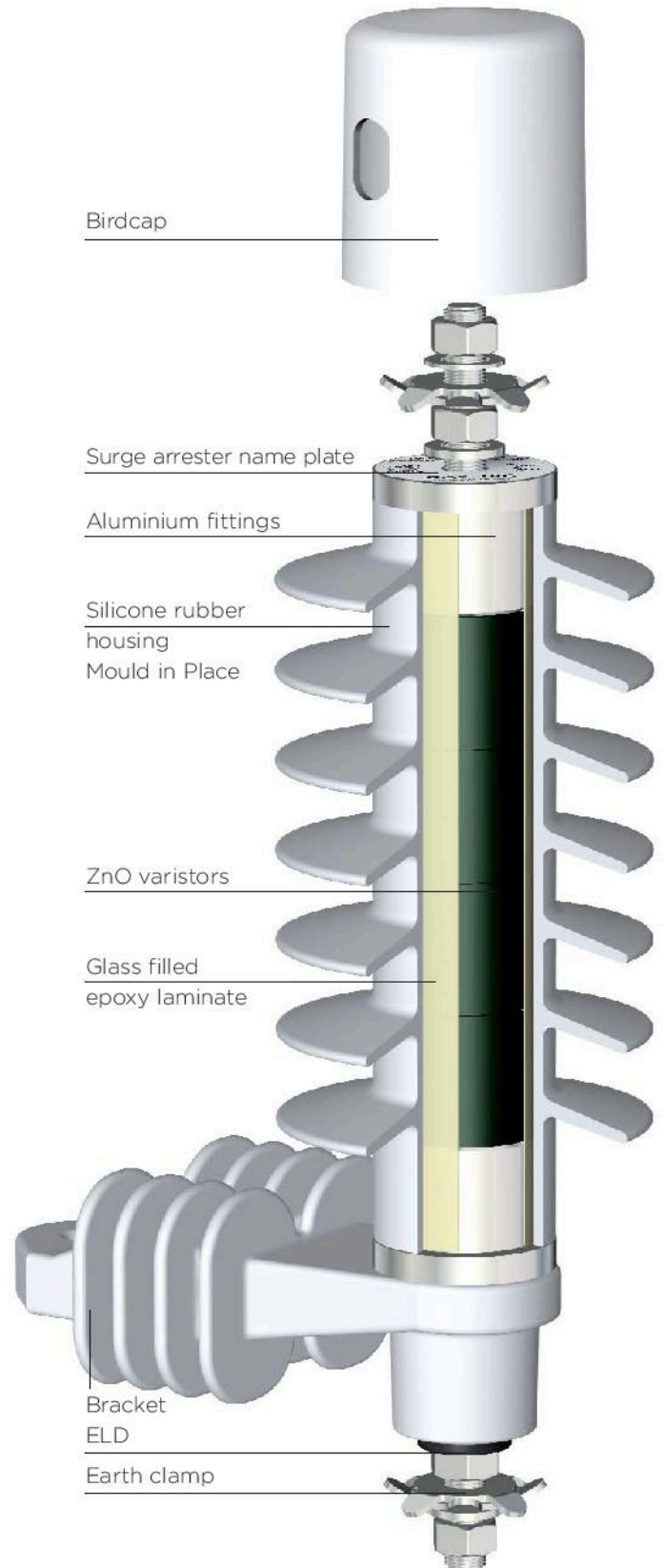

**Application:**

Protection of MV networks and equipment from lightning and switching surge related over-voltages. Designed and optimised to protect distribution assets including transformers and cable-end terminations.

Generic technical data:

DA1 series	4 - 45 kV
Rated discharge current (8/20µs):	10 kA
Line discharge class 1 according to	IEC 60099-4 (2006)
Operating duty impulse withstand current (4/10µs):	100 kA
Long duration current impulse (2000µs):	325 A
10 second TOV, (UTOV / Uc)	1.29 * Uc
High current short circuit: (pre-failing method) (Safe non-shattering failure mode)	21 kA
Energy	5.6 kJ/kV

Mechanical data

Cantilever (Nm)	350Nm
Tension (N)	2000N
Torque (Nm)	50Nm

**Bowthorpe EMP DA1 series surge arrester benefits:**

**Tested in accordance with IEC60099-4 at independent accredited laboratories**

**Direct moulded housing to prevent moisture ingress**

**Low residual voltages**

**High-energy handling**

**Safe non-shattering short circuit behavior to higher current levels**

**Maintenance free**

**Hydrophobic silicone housing: (Tracking and erosion resistant)**

**Excellent cantilever and tensile performance**

**Quality design and manufacturing meeting international standards**

**TOV of DA1 with 100kA single shot high current prior energy**

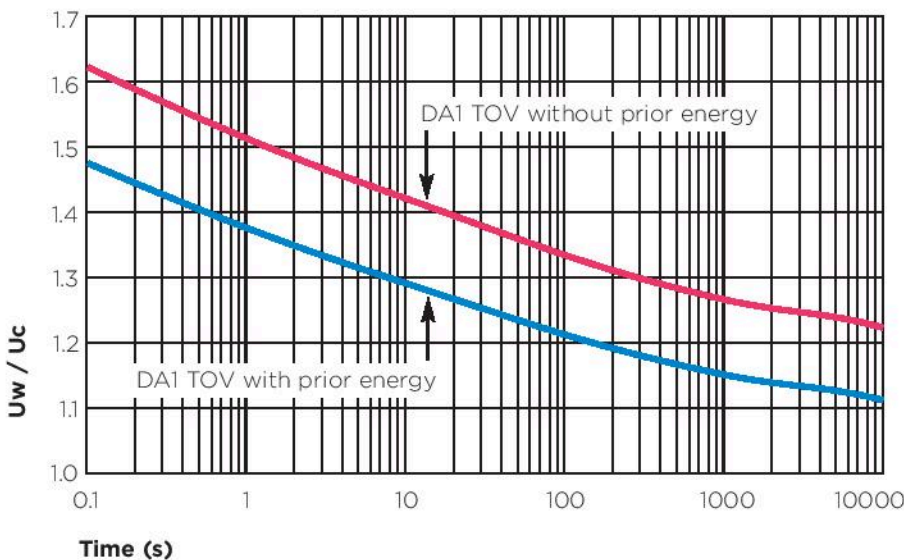

Temperature of samples (pre-heated): 60° C according to IEC 60099-4, Ed 2.1 2006. TOV Curve applies to an arrester which has a pre-stress applied prior to TOV verification. This pre-stress is equivalent to one high current impulse of 100kA, 4/10 as per the operating duty test.

Uw = TOV withstand voltage; Ur = Rated voltage

**Sample product marking, DA1-30F**

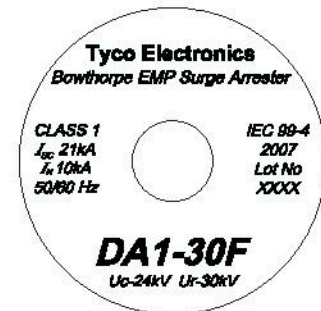

# Reliability, quality and protection excellence

## DA1 series arrester standard electrical data:

Part Number	Uc kV	Ur kV	Residual voltage in kV when tested to the following test waveforms						TOV 100s kV	
			Lightning (8/20µs)			Steep (1/20µs)		Switching (30/60µs)		
			5kA	10kA	20kA	10kA	125A	500A		
DA1-04	3.2	4	10.0	10.6	11.6	11.1	8.0	8.4	3.9	
DA1-06	4.8	6	14.9	15.9	17.4	16.7	12.0	12.7	5.8	
DA1-08	6.4	8	19.9	21.2	23.2	22.3	15.9	16.9	7.8	
DA1-10	8.0	10	24.9	26.5	29.1	27.9	19.9	21.1	9.8	
DA1-12	9.6	12	29.9	31.8	34.9	33.4	23.9	25.3	11.7	
DA1-15	12.0	15	37.3	39.8	43.6	41.8	29.9	31.6	14.7	
DA1-18	14.4	18	44.8	47.7	52.3	50.2	35.9	38.0	17.6	
DA1-21	16.8	21	52.3	55.7	61.0	58.5	41.9	44.3	20.5	
DA1-22	17.6	22	54.8	58.3	63.9	61.3	43.9	46.4	21.6	
DA1-24	19.2	24	59.7	63.6	69.7	66.9	47.8	50.6	23.5	
DA1-27	21.6	27	67.2	71.6	78.4	75.2	53.8	56.9	26.4	
DA1-30	24.0	30	74.7	79.5	87.2	83.6	59.8	63.3	29.4	
DA1-33	26.4	33	82.1	87.5	95.9	92.0	65.8	69.6	32.3	
DA1-36	28.8	36	89.6	95.4	104.6	100.3	71.8	75.9	35.2	
DA1-39	31.2	39	97.1	103.4	113.3	108.7	77.7	82.2	38.2	
DA1-42	33.6	42	104.5	111.3	122.0	117.0	83.7	88.6	41.1	
DA1-45	36	45	112.0	119.3	130.7	125.4	89.7	94.9	44.1	

## DA1 series arrester standard housing parameters:

Housing code	Number of sheds	Creepage mm	Flash over distance mm	Dry impulse withstand voltage (1.2 / 50) kV	Power frequency voltage withstand (wet) kV	Height mm	Weight (approx.) kg
A	4	329	152	134	50	147	1.2
B	5	404	177	160	56	172	1.4
C	7	553	227	194	66	222	1.8
D	8	627	252	205	75	247	2.0
E	9	702	277	229	92	272	2.2
F	10	776	302	247	102	297	2.6
G	12	925	352	273	122	347	2.9
H	14	1074	402	295	135	397	3.4

## Housing and Ur compatibility:

Ur	Housing code: Creepage:	A 329	B 404	C 553	D 627	E 702	F 776	G 925	H 1074
4		●	■						
6		●	■						
8		●	■	■					
10		●	■	■					
12		●	■	■	■				
15			●	■	■	■			
18			■	●	■	■	■		
21				■	●	■	■		
22				■	●	■	■	■	
24				■	■	●	■	■	
27					■	■	●	■	■
30					■	■	●	■	■
33						■	■	●	■
36						■	■	●	■
39							■	■	●
42								■	●
45								■	●

● standard housing      ■ optional housing

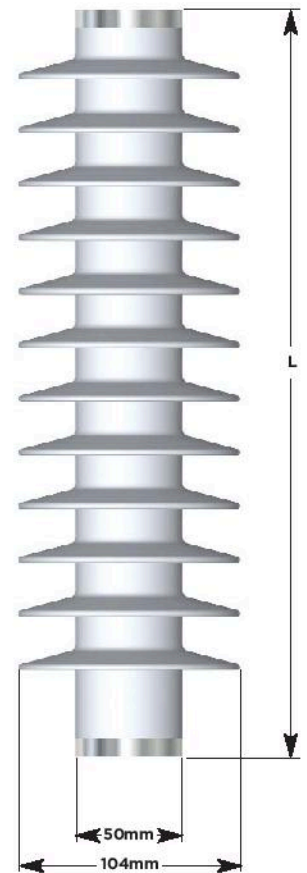

# DA1 series arrester ordering information and accessory selection table:

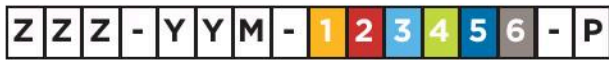

## Naming convention cross reference:

ZZZ = series type: DA1 for 10kA, class1 arrester.  
 YY = Ur  
 M = Housing code

### 1 Line lead accessories

Bxxxx Birdcap with F accessory	Exxxx Birdcap with M accessory	Fxxxx 45mm stud for lug connection	Hxxxx Cap screw & Spring Washer	Mxxxx 45mm stud for line lead connection	Oxxxx No Stud. No Accessories	Pxxxx S-Clamp	Qxxxx L-Clamp

### 2 Line lead options

x0xxxx	No Line Lead Wire
x1xxxx	0.5m 16mm <sup>2</sup> Copper Line Lead & one M12 lug
x2xxxx	1m 16mm <sup>2</sup> Copper Line Lead & one M12 lug
x3xxxx	1m 16mm <sup>2</sup> Copper Line Lead & no lug
x4xxxx	0.5m 35mm <sup>2</sup> Copper Line Lead & one M12 lug
x5xxxx	1m 35mm <sup>2</sup> Copper Line Lead & one M12 lug
x6xxxx	1m 35mm <sup>2</sup> Copper Line Lead & no lug

### 3 Earth lead accessories:

xxDxxx Disconnect + M accessory	xxExxx Disconnect + F accessory	xxFxxx 45mm stud for lug connection	xxHxxx M12*25 Cap screw & Spring Washer	xxMxxx 45mm stud for line lead connection	xxOxxx No Stud. No Accessories

### 4 Earth lead options

xxx0xx	No Earth Lead Wire
xxx1xx	0.5m 16mm <sup>2</sup> Copper Earth Lead & one M12 lug
xxx2xx	1m 16mm <sup>2</sup> Copper Earth Lead & one M12 lug
xxx3xx	1m 16mm <sup>2</sup> Copper Earth Lead & no lug
xxx4xx	0.5m 35mm <sup>2</sup> Copper Earth Lead & one M12 lug
xxx5xx	1m 35mm <sup>2</sup> Copper Earth Lead & one M12 lug
xxx6xx	1m 35mm <sup>2</sup> Copper Earth Lead & no lug

### 5 Mounting brackets:

xxxxAx Straight 2 hole Mounting Bracket	xxxxBx Insulating bracket	xxxxCx DIN metal bracket, (galvanised)	xxxxNx No Mounting Accessories	xxxxPx Pedestal Mounting Base

### 6 Mounting bracket options:

xxxxx0 No Option	xxxxx1 NEMA Cross Arm Bracket	xxxxx6 T - mounting bracket

### Packaging

I	Individual Packing
S	3 Pack
B	Bulk Packing

Additional accessories are available on request from [surgearresters@tycoelectronics.com](mailto:surgearresters@tycoelectronics.com)

# DA1 series arrester accessories dimensions

**Fxxxx & xxFxxxx:**  
Stainless steel lug connection

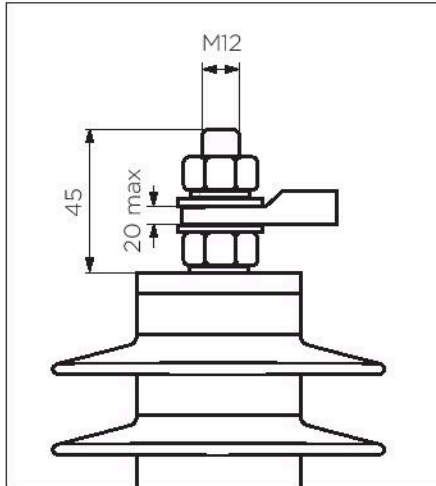

**Hxxxx & xxHxxx:**  
Cap screw connection

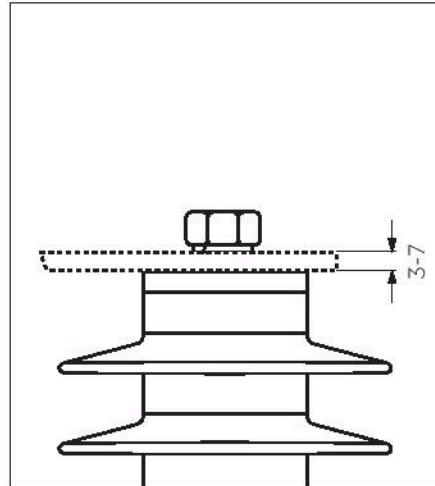

**Mxxxx & xxMxxxx:**  
Stainless steel line lead connection,  
(up to diameter 16mm)

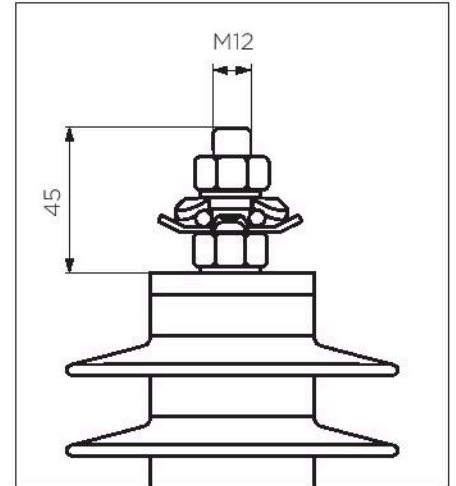

**Oxxxx & xxOxxx:**  
No accessories

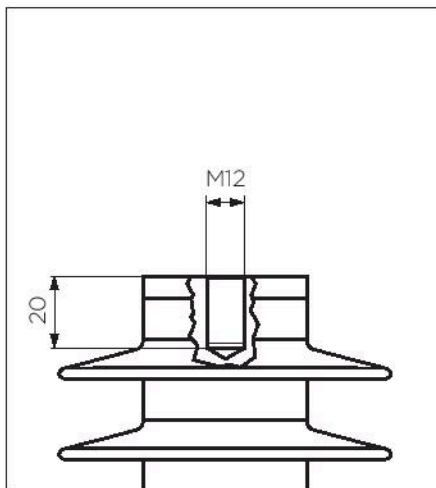

**Pxxxx:**  
Stainless steel S clamp,  
(up to diameter 8-17mm)

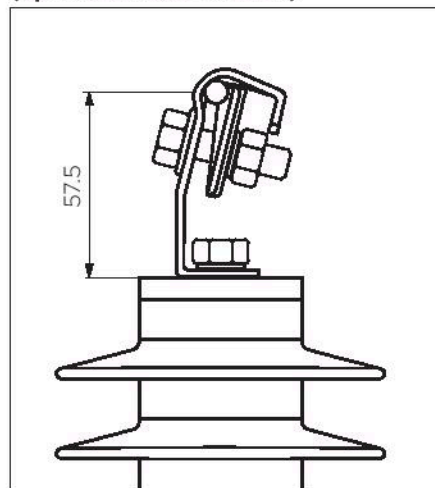

**Qxxxx:**  
Stainless steel Q clamp,  
(up to diameter 8-16mm)

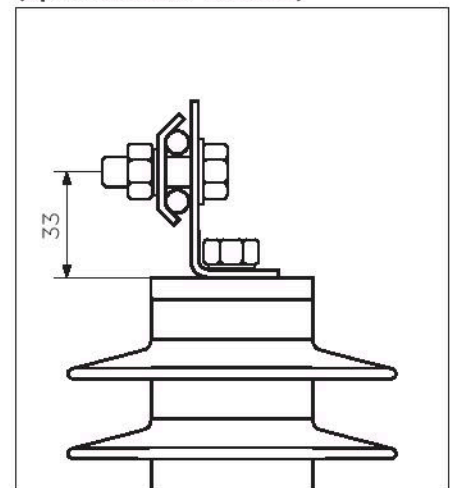

**xxxxAx:**  
Galvanized steel Straight 2hole  
mounting metal bracket

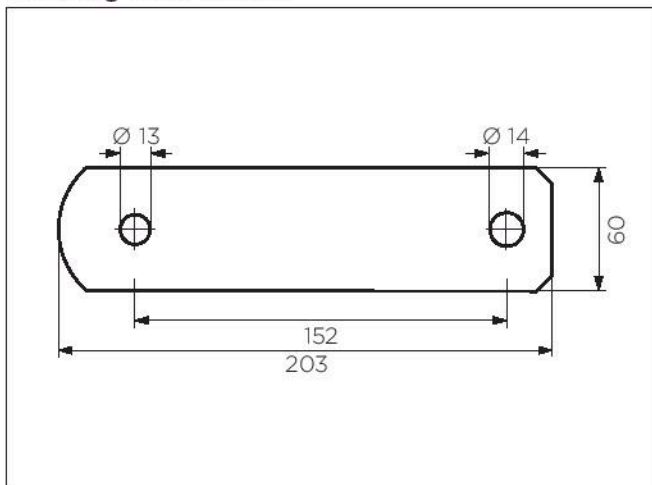

**xxxxCx:**  
Galvanized steel DIN metal bracket

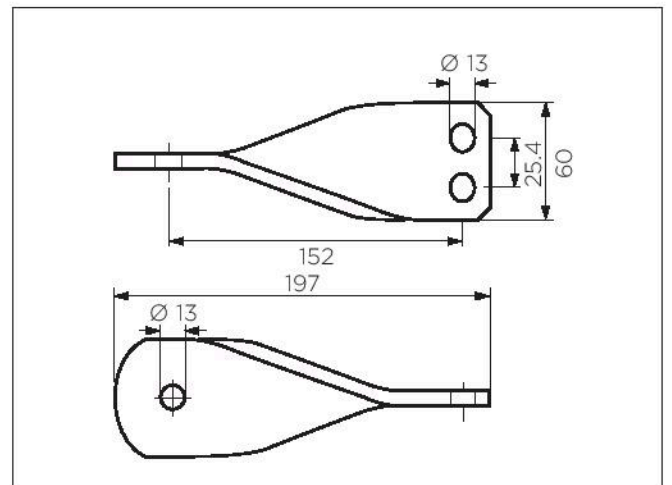

All dimensions in mm.

For addition accessory options,  
please contact support team at:  
[surgearresters@tycoelectronics.com](mailto:surgearresters@tycoelectronics.com)

# DA1 series arrester accessories dimensions

**Bxxxx & Exxxx:**  
Tracking and erosion resistant  
bird protection cover

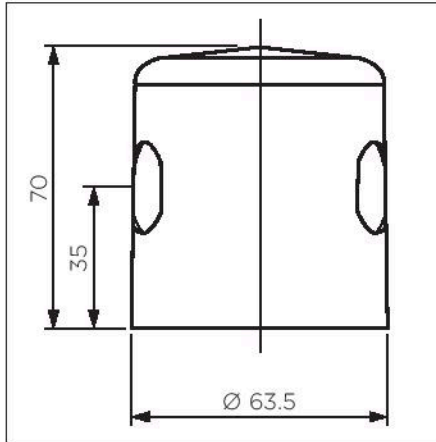

**xxDxxx and xxExxx:**  
earth lead disconnect

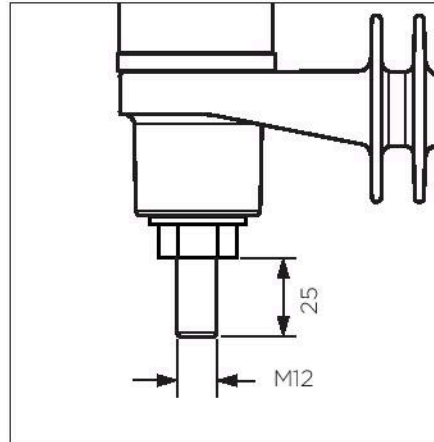

**xxxxEx:**  
Stainless steel DIN metal bracket

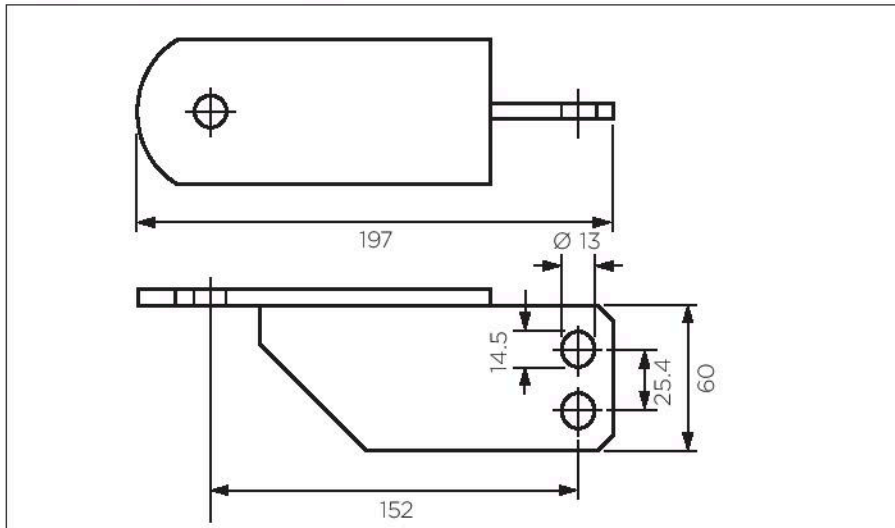

**xxxxx6:**  
Galvanized steel T metal bracket

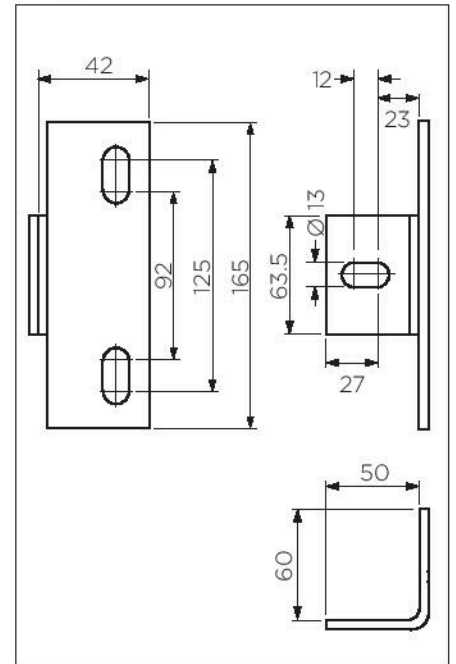

**xxxxx1:**  
Galvanized steel NEMA cross arm mounting bracket

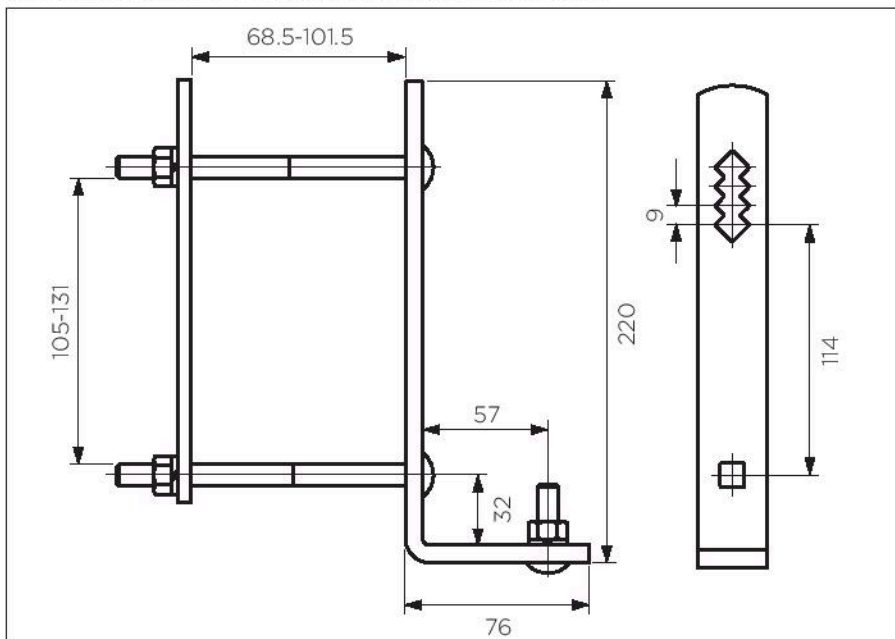

All dimensions in mm.

For addition accessory options,  
please contact support team at:  
[surgearresters@tycoelectronics.com](mailto:surgearresters@tycoelectronics.com)

# DA1 series arrester accessories dimensions

xxxxBx:  
Insulating brackets

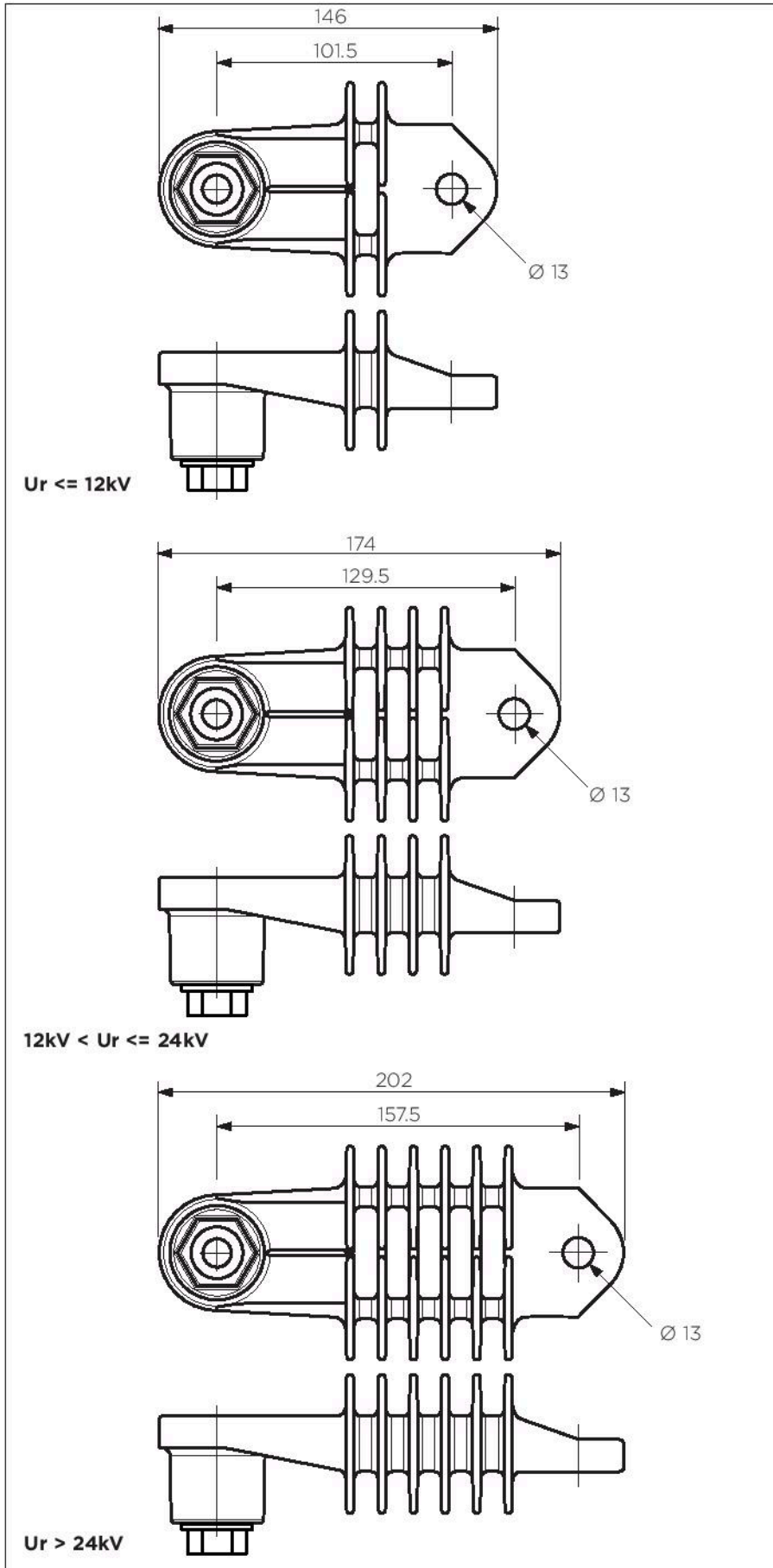

**Note:**  
xxxxBx can only be used with either xxDxxx or xxExxx accessory.

All dimensions in mm.

For addition accessory options, please contact support team at: [surgearresters@tycoelectronics.com](mailto:surgearresters@tycoelectronics.com)

## Other Bowthorpe EMP distribution surge arrester products

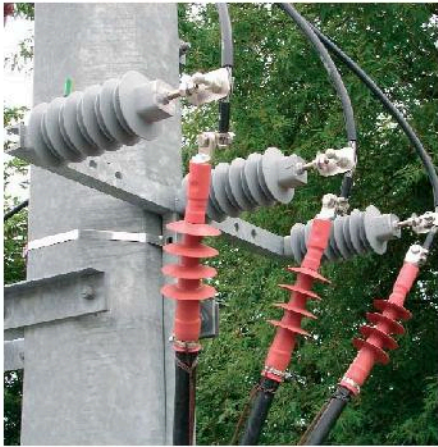

Typical application



Tracking and erosion test



Hydrophobic silicone

### Class 2 OCP series arrester

Bowthorpe EMP OCP2 surge arresters are used in overhead line to cable junction and substation protection application. These arresters are manufactured using high energy and low residual voltage ZnO varistors, which display excellent thermal and current handling characteristics, delivering optimal protection.

Generic technical data:

OCP2 series	3-41kV U <sub>c</sub>
Rated discharge current (8/20μs):	10kA
Line discharge class 2 according to	IEC 60099-4
Operating duty impulse withstand current (4/10μs):	100kA
Long duration current impulse (2000μs):	530A
High current short circuit: (pre-failing method) (Safe non-shattering failure mode)	40kA
Energy	2 Long duration impulses: 6.0kJ/kVU <sub>c</sub>



Typical application



without CLX



with CLX

### Protection for covered conductor systems

Bowthorpe EMP CLX protection for covered conductor systems is designed to use as a lightning protection in overhead lines with covered conductors, designed to prevent conductor breaking.

Generic technical data:

CLX / MORE series	11-33kV systems
Rated discharge current (8/20μs):	10kA
Operating duty impulse withstand current (4/10μs):	65kA
Long duration current impulse (1000μs):	250A
High current short circuit: (pre-failing method)	25kA
Energy	2 Long duration impulses: 2.9kJ/kVU <sub>c</sub>

**Overview of ZnO surge arresters offered by Tyco Electronics Energy Division**

Type	Application	Rating [kA]	Line discharge class	Continuous voltage [kV] from to	
MV arresters for outdoor application					
DAO	Outdoor standard silicone 5kA application	5	n.a.	2.4	9.6
DA1	Outdoor standard class 1 application	10	1	3.2	36
HDA	Outdoor high pollution application	10	1	3	41
OCP2	Outdoor Cable and substation protection	10	2	3	41
Arresters for protection systems					
CLX	Protection of covered conductor systems	10	1	3	36
MV arresters for indoor application					
RDA	Protection of gas insulated switchgear	10	1	3	26
SPA	Protection of air insulated switchgear	10	1	3	36
MPA	Motor protection	10	1	3	6
CPA	Cable sheath protection	10	1	3	6
RSTI-SA	Screened separable surge arrester	5, 10	n.a.	12	24
LV arresters					
LVA	Transformer secondary protection	10	n.a.	0.28	0.441
Arresters for railway application					
HE60	DC railway protection	10	n.a.	1	6



**Tyco Electronics’ Energy Division total commitment to quality**

Even the best technology must be backed up by a thorough and consistent quality assurance program. At Tyco Electronics, we subject every product to an extensive quality control regimen which includes the following procedures: At every production stage, beginning with the raw materials and continuing through to the packaged product, the QC lab tests all physical and electrical characteristics which can influence quality.

By means of lot numbers the Quality Assurance Program ensures traceability backwards all the way to the details of the compound batch test reports. Quality assurance at Tyco Electronics is not a static, but rather a constantly improving process directed towards our goals: complete customer satisfaction. Tyco Electronics Energy Division arrester manufacturing sites are accredited to international quality standards. Our vendor routine tests and internal incoming inspection confirm performance of all critical components used in the assembly of our arresters.

## Other products and brochures available from Tyco Electronics Energy Division

### Asset protection

Insulation enhancement systems for substations and overhead. Designed to prevent unplanned outages due to accidental bridging and to help upgrade insulation levels at critical points in systems.

Contact us at: [assetprotection@tycoelectronics.com](mailto:assetprotection@tycoelectronics.com)



### Low-voltage surge arresters

LV arresters are used to provide protection for LV overhead lines, consumer in-house supplies, distribution transformers and other appliances.

Contact us at: [surgearresters@tycoelectronics.com](mailto:surgearresters@tycoelectronics.com)



### Medium-voltage surge arresters

Metal oxide varistor, distribution arresters for indoor and outdoor applications for protection of overhead lines, DC locomotives and switchgear applications.

Contact us at: [surgearresters@tycoelectronics.com](mailto:surgearresters@tycoelectronics.com)

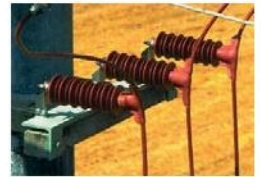

### High-voltage surge arresters

Porcelain and polymeric series parallel and single column constructed arresters for protection of transmission systems up to 550 kV.

Contact us at: [hvsurgearrester@tycoelectronics.com](mailto:hvsurgearrester@tycoelectronics.com)



### Polymeric insulators

Insulators and insulating components/housings providing reliable solutions for power utilities and railway customers with installations in high pollution environments and applications up to 400 kV.

Contact us at: [insulators@tycoelectronics.com](mailto:insulators@tycoelectronics.com)



### Porcelain insulators

Insulators for applications up to system voltages of 132 kV. This range of insulators offers a cost-effective solution for low and medium polluted environments.

Contact us at: [insulators@tycoelectronics.com](mailto:insulators@tycoelectronics.com)



While Tyco Electronics and its affiliates referenced herein have made every reasonable effort to ensure the accuracy of the information contained in this catalog, Tyco Electronics cannot assure that this information is error free. For this reason, Tyco Electronics does not make any representation or offer any guarantee that such information is accurate, correct, reliable or current. Tyco Electronics reserves the right to make any adjustments to the information at any time. Tyco Electronics expressly disclaims any implied warranty regarding the information contained herein, including, but not limited to, the implied warranties of merchantability or fitness for a particular purpose. Tyco Electronics' only obligations are those stated in Tyco Electronics' Standard Terms and Conditions of Sale. Tyco Electronics will in no case be liable for any incidental, indirect or consequential damages arising from or in connection with, including, but not limited to, the sale, resale, use or misuse of its products. Users should rely on their own judgement to evaluate the suitability of a product for a certain purpose and test each product for its intended application. In case of any potential ambiguities or questions, please don't hesitate to contact us for clarification. Bowthorpe EMP, Raychem, TE (logo) and Tyco Electronics are trademarks of the Tyco Electronics group of companies and its licensors.

**Energy Division – innovative and economical solutions for the electrical power industry: cable accessories, connectors & fittings, insulators & insulation, surge arresters, switching equipment, lighting controls, power measurement and control.**

Tyco Electronics Raychem Ireland Ltd.  
MV Product Management  
Bay 105 Shannon Industrial Estate  
Shannon, Co. Clare, Ireland

E-mail: [surgearresters@tycoelectronics.com](mailto:surgearresters@tycoelectronics.com)

<http://energy.tycoelectronics.com>

Marketed by :-  
**ATP Thermtech Private Limited.**  
R-15, Ritu Complex, Main Market, Shakarpur,  
New Delhi -110092 (INDIA)  
PH. NO.: 011 - 42401674  
E-mail - [info@atpindia.net](mailto:info@atpindia.net) / [sales@atpindia.net](mailto:sales@atpindia.net)  
Website : [www.atpthermtech.com](http://www.atpthermtech.com)

 **Tyco Electronics**  
Our commitment. Your advantage.